Colorado K-12 Broadband White Paper

High-Speed Bandwidth Access and Growth

ABSTRACT

Colorado school districts currently experience a wide range of broadband connectivity options. From individual districts' building to building enterprise Wide Area Network (WAN) to each district's broadband connectivity to its Internet Service Provider (ISP) of choice. The cost structure that each school district faces vary based upon the diversity of the number and type of available connectivity options.

Rural Colorado districts may experience local WAN (or intra-district WAN) connectivity that is only available from one single provider, with limitations as to growth potential and at costs as high as \$800 per 1 Mbps of service. Urban districts may benefit by having competitive WAN offerings by multiple providers at or below \$100 per 1 Mbps of service. In addition to this intra-district WAN cost disparity, access to an ISP connection with its dependence on variable broadband infrastructure components needed to deliver the final connection to the ISP, the end-to-end district to ISP connection cost (between urban and rural districts) are again as far apart as was shown in the intra-district WAN example.

According to the 2007 National Digital Schools survey, the need for Broadband connectivity in schools will increase more than 7 times by the year 2011.¹ This would mean for a district currently connected on a T-1 circuit (1.5 Mbps) intra-district connection coupled with the 1.5 Mbps ISP connection (paying approximately \$1,350 per month for the combined connections) the district would need to grow its intra-district WAN and ISP combined bandwidth to approximately 10 Mbps per each network transport segment to meet this projected growth requirement. Assuming there is no additional infrastructure development within our rural environment, the intra-district WAN & ISP cost would increase to over \$10,000 per month (presuming there is an ability to grow to the 10 Mbps connection). If, as in our example district, they were already struggling to fund the 1.5 Mbps connection, how can this district tackle the 10 fold price increase?

Our rural model is completely inverted when it comes to the districts serving the densely populated corridors within the Denver metropolitan urban area. The same 10 Mbps intra-district WAN and ISP connection to the urban district would cost between \$1,650 to \$1,800 per month, depending on the competitive providers and the type of network connection. The other skewed element is that the urban districts will most likely have the ability to grow their connections by 10 to even 100 fold (in comparison to rural districts) at a cost that results in a declining price per 1 Mbps of service, again depending on the type of network connection. Of course, this growth is dependant on the urban district having the funding to pay for the larger bandwidth connection.

¹America's Digital Schools 2008, © 2008 The Greaves Group, The Hayes Connection, available at: <http://www.ads2006.org/ads/index.php>

So what is the best approach to solve this broad based statewide dilemma? A viable approach would be the development of a cost sharing consortium. This would provide the capability for districts to work together to pool their needs and purchase concentrated amounts of larger bandwidth at strategic points of connectivity to be more effectively packaged and delivered to a broader distributed base of common aggregation points.

A simplified worst case view of the rural district broadband infrastructure elements necessary to individually support rural districts is shown in diagram 1.1 below.

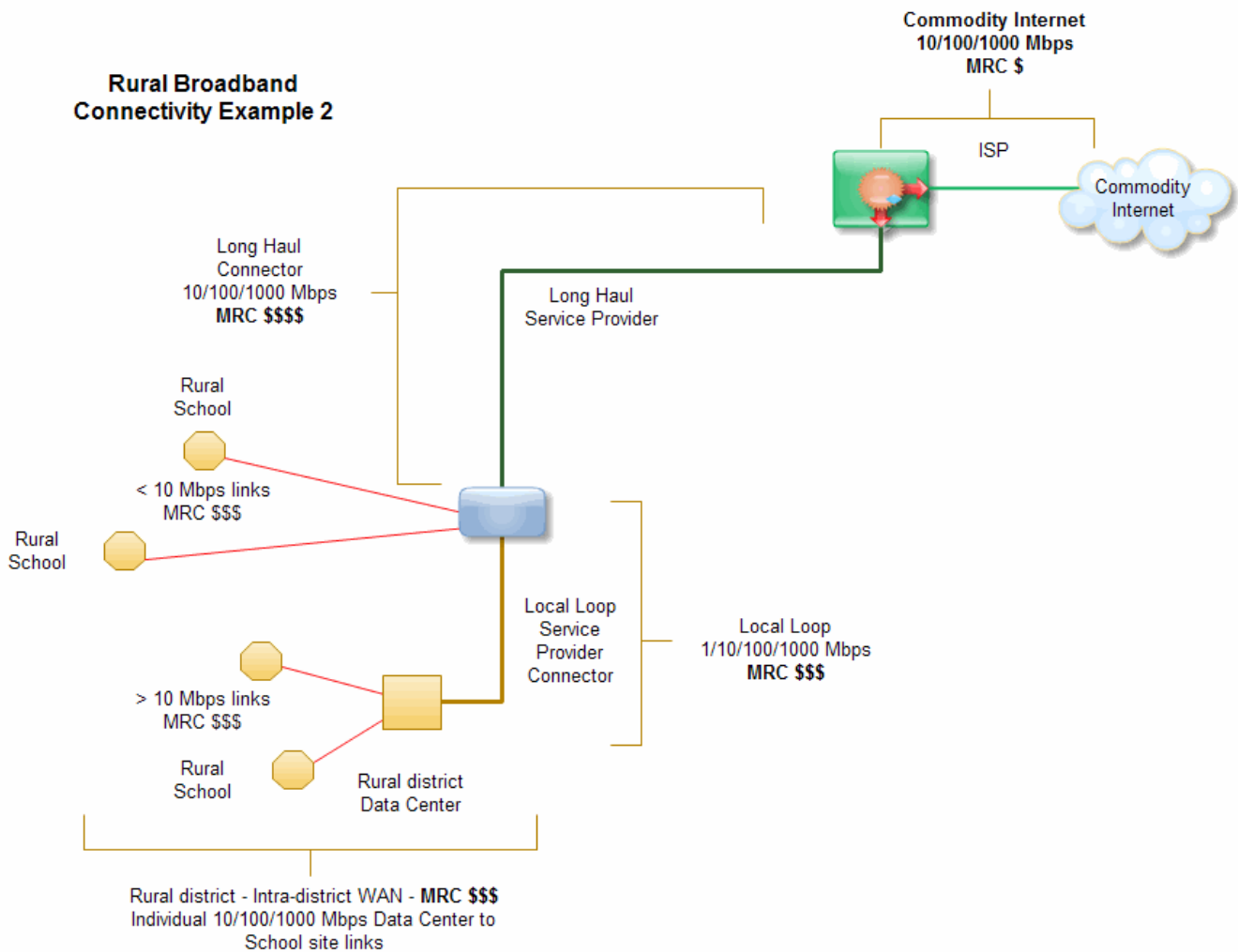

Diagram 1.1 – Rural Broadband Example

In contrast to the (previous) rural example, a simplified view of the broadband infrastructure elements necessary to support the urban district is shown below in diagram 1.2.

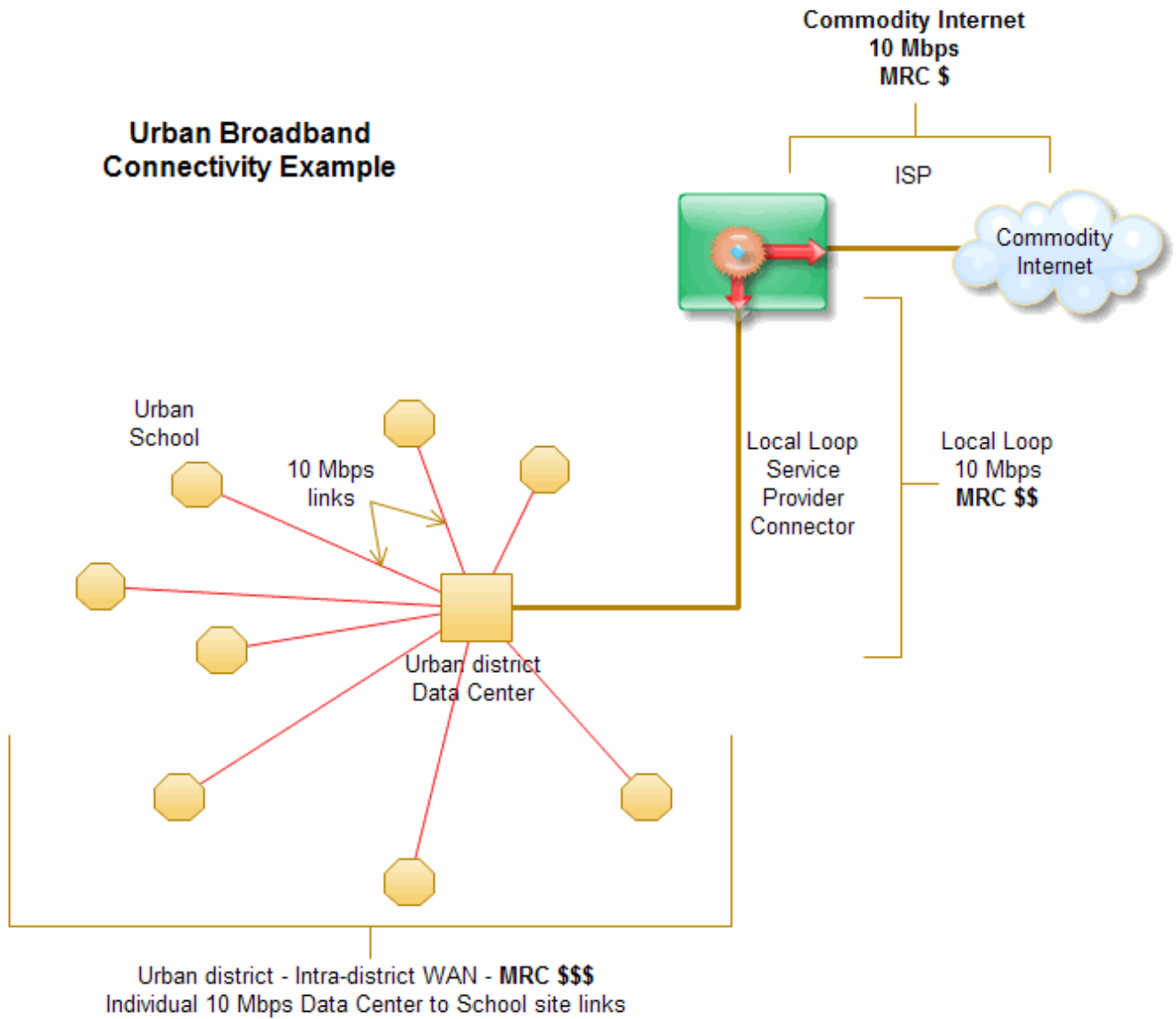

Diagram 1.2 – Urban Broadband Example

CONNECTIVITY DYNAMICS – REALITY ON THE GROUND

Colorado has 64 counties and 178 recognized public school districts. In order to effectuate long term and sustainable change and improvements in ubiquitous access to bandwidth to accommodate both urban and rural districts, a level of collaborative purchasing power that allows for the cost-sharing mechanisms needs to be established at one or more of the common infrastructure points. Instead of having 178 independent approaches to fulfilling bandwidth at varied costs, we can scale down to a smaller number of coordinated infrastructure points; these points are where decisions on how to develop, apply leverage on providers, and affordably cost share the greater bandwidth accessibility at common locations become less fragmented.

One of the cornerstone elements of connectivity is the final connection to the commodity Internet and other non-commercial education and R&D national backbone networks that are designed to be less congested than the commercial or commodity Internet. The Internet2 and the National Lambda Rail Network (NLR) networks serve this purpose and provide high bandwidth access at low costs as they have multiple institutional cost sharing components enabled at institutional levels of connectivity. Diagram 1.3 below shows the representation of many of the network connections that form Internet2.

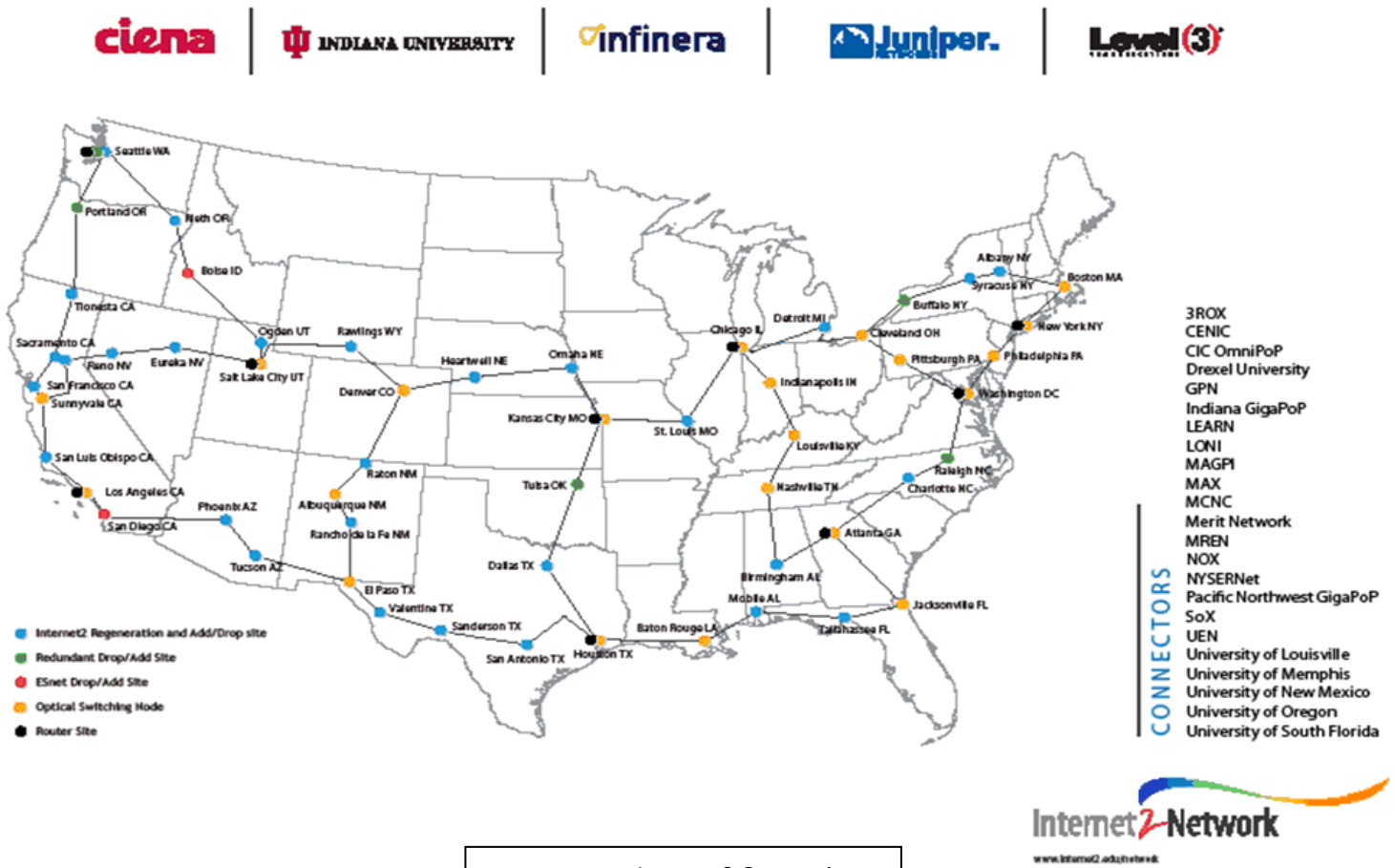

Diagram 1.3 – Internet2 Connections

From November of 2006 to May of 2007, Centennial BOCES (a consortium of 15 member school districts in the Northeastern part Colorado representing more than 50,000 students) on behalf of its member districts and several Colorado Front Range school districts, worked with the manager of the Front Range GigaPoP (FRGP) and network engineers from the University Corporation for Atmospheric Research (UCAR) to establish a network aggregation model for all K-12 school districts in Colorado.

Through UCAR's support and a physical aggregation hub in Denver, Colorado, the UCAR Point of Presence (UPoP) establishes the network gateway for Internet2 and NLR access, as well as, provides the opportunity for all 178 districts to have an intra-state private network connected via a common network aggregation point.

An intra-state private K-12 network could allow for:

- delivery of inter-district distance learning under a common management platform
- Higher Ed and Community Colleges to extend distance learning via high-definition video conferencing to the classroom with more stable broadband connections
- district-to-district and district to Department of Education on-line data posting, sharing, and archival

While this solves one dilemma for K-12 districts in Colorado another remains. How do we establish a better cost sharing collaboration between school districts at the high-speed broadband level? There needs to be some way to coordinate this great potential to effectuate collaboration, resource sharing, and development of the network interconnectivity.

In September of 2007, UCAR working with Centennial BOCES enabled a network connection that would allow the K-12 network gateway located in Denver to be the managed network connection for K-12 and became known as the Educational Access Gateway Learning Environment Network, or "EAGLE-Net" (<http://www.co-eaglenet.net/>). The EAGLE-Net structure is comprised of both Educational collaborative relationships between Colorado's K-12 and Higher Ed environments and with the State's Telemedicine network via an intra-state networking consortium.

Diagram 1.4, shown on the following page, is a simplified view of how EAGLE-Net connects to the FRGP.

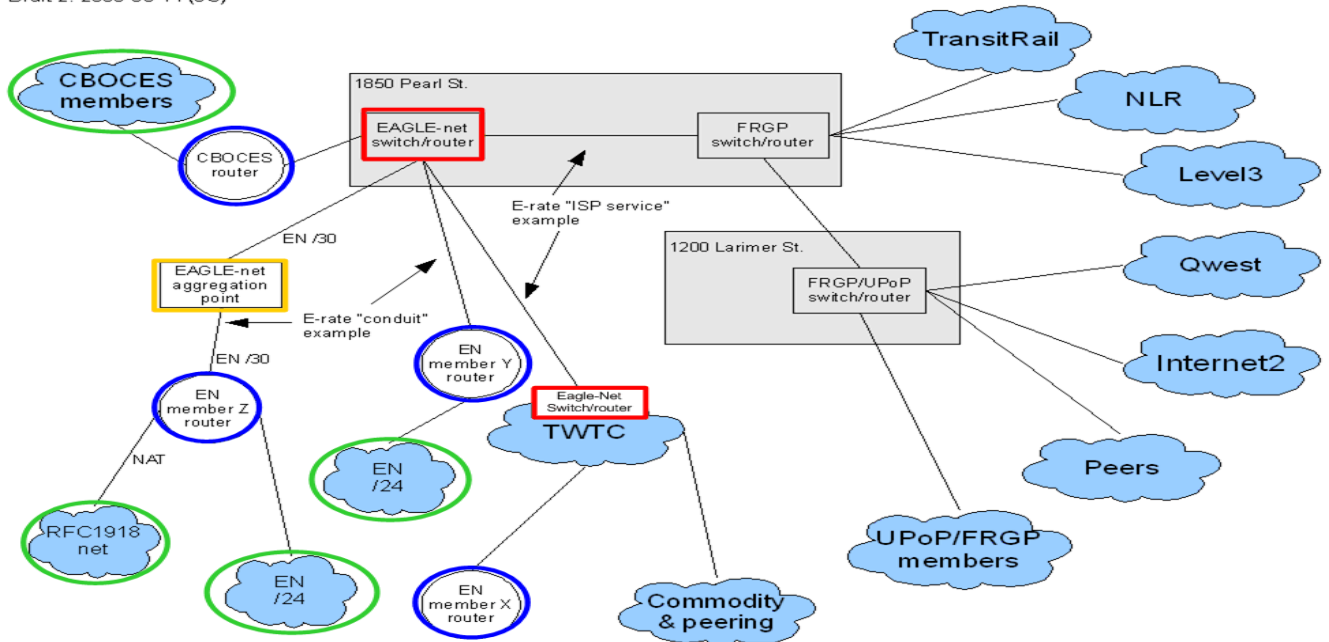

Diagram 1.4 – EAGLE-Net Connections

As part of the on-going Centennial BOCES K-12 network assessment and E-rate planning process (to use the EAGLE-Net consortium with Centennial BOCES non-profit ISP status to deliver statewide EAGLE-Net connections), networking connectivity alternatives have been identified by carrier and/or operator along with logical co-location facilities and existing aggregation points, primarily East of I-25 from the New Mexico border to the Wyoming border and to the Kansas/Nebraska state lines. Transport types, available bandwidth, delivered bandwidth, and bandwidth growth were as diverse as the forms of connection delivery (i.e. low bandwidth frame relay, high bandwidth copper and fiber digital connections, fiber optic based Ethernet, point-to-point licensed microwave, unlicensed point-to-multi-point microwave). Delivery of connectivity/transport types in the last mile and up to a point of regional aggregation included common carriers, cable television operators, state and local government traffic and transportation groups, municipal electric co-ops, rural telephone co-ops, licensed microwave operators, long haul fiber providers, and Higher-Ed (e.g., Colorado State University (CSU) and Colorado Department of Transportation (CDOT) Inter-Governmental long haul cooperative). At this time, the CSU/CDOT long haul cooperative and the Centennial BOCES member aggregation are the only cost sharing environments that connect to the FRGP via a formal cost-sharing environment.

There is a continuing need and a constant effort in place through Centennial BOCES, UCAR, and CSU to try and leverage what many existing regional cost sharing K-12 cooperatives have created (within their educational regions) and take the next step to find and/or deliver an effective "long-haul" connector to either another aggregation point to interconnect to EAGLE-Net or to directly connect to EAGLE-Net.

CONSORTIUM BASED COST SHARING - DIRECT AND IN-DIRECT BENEFITS

By establishing the EAGLE-Net Gateway, K-12 school districts, BOCES, and the Colorado Department of Education (CDE) can receive direct technical, educational, and resource sharing benefits through:

- Statewide K-12 network interconnection for collaboration;
- Cost sharing connectivity, applications and data, content, and technical resources;
- Enhanced teacher and student capabilities through ease of access to advanced network applications, services, tools, and educational resources;
- Consortium ISP/Internet2 and NLR costs decreases with more bandwidth purchased through the consortium;
- Long Haul transport costs per entity reduce with more aggregation;
- District level participation in the EAGLE-Net Gateway consortium is a voice for technical and instructional participation in program and application development;
- Standards based interconnection, content sharing, and distribution;
- Commercial peering;
- Real time management and support of infrastructure, connections and programs with portal based user interface for bandwidth utilization, trouble shooting and management; and
- Data warehousing, disaster recovery, and business resumption on a multi-tiered and multi-regional basis.

STATEWIDE K-12 CONNECTIVITY, COLLABORATION AND PARTICIPATION DOES EXIST

The following statewide consortium models are currently in existence, connected via high-speed broadband links (on-net) within the K-12 statewide internetworking environment and are collaborating under a cost sharing model both within the state and across the Internet2 and NLR networks with other K-12 districts nationally:

- Utah – Utah Education Network (UEN; <http://www.uen.org/>)
- Missouri – MoreNet (<http://www.more.net/>)
- Nebraska – Nebraska Net (<http://www.networknebraska.net/>)
- Pennsylvania – Magpi (<http://www.magpi.org/>)
 - Our mission is to deliver regional infrastructure in a cost-effective manner and promote applications for the region's research and education communities through high performance network technology.

-
- Rhode Island – RINet (<http://www.ri.net/>)
 - California – CENIC (<http://www.cenic.org/>)

Centennial BOCES/EAGLE-Net and UPoP management have been working to provide K-12 schools (among other non-profit and governmental entities) a much needed Sponsored Education Group Participant (SEGP; <http://k20.internet2.edu/about/segp/>) membership to access and use the Internet2 network resources available directly to K-12 members. The Internet2 membership is anticipated to be available by July 2009. With this membership Colorado K-12 school districts will be able to take advantage of the K-20 Initiative which brings together Internet2 member institutions and innovators from primary and secondary schools, colleges and universities, libraries, and museums to extend new technologies, applications, middleware, and content to all educational sectors, as quickly and connectedly as possible.

During the last quarter of 2008, Centennial BOCES initiated, developed, and completed its initial network aggregation and educational networking plan to have the EAGLE-Net become a statewide K-12 aggregator. In December, the American Registry for Internet Numbers (ARIN) granted and assigned an initial /20 IPv4 IP address block to EAGLE-Net. EAGLE-Net will have the ability to request additional /20 IPv4 IP address blocks as a part of growth that continues to occur with more EAGLE-Net participants. Centennial BOCES is in the process of deploying the new IPv4 address blocks to existing EAGLE-Net members who in turn will release other carrier provided IP addresses back to respective carriers in an effort to transition to the EAGLE-Net Colorado intra-state K-12 network.

Establishing recognition and approval from ARIN will provide a long term capability to maintain growth, continuity, and management capability for the Colorado K-12 EAGLE-Net membership. Centennial BOCES has also positioned EAGLE-Net strategically to be able to convert EAGLE-Net aggregation locations to IPv6 addressing, via a migration plan that was also acceptable to ARIN. EAGLE-Net will monitor IPV6 adoption and when the IPv6 IP addressing scheme is more widely adopted within the Internet, EAGLE-Net will be positioned to make a less disruptive transition to the new addressing standard.

ONGOING EAGLE-Net INTERCONNECTION AND DEVELOPMENT NEEDS

EAGLE-Net has been applying for and leveraging Federal and State grant programs along with private Foundation grant and loan programs to cover portions of the start up costs for establishing co-location, multiple forms of network connectivity, engineering, and design. Various networking equipment hardware manufacturers, municipal and electric power communications entities, and communications carriers have provided in-kind hardware donations, public benefit based cost reduced service charges, and racks/other inter-networking components to date to help EAGLE-Net continue and grow. However, the following ongoing interconnection and collaborative development needs still exist:

- Active K-12 representatives and participants in the EAGLE-Net Steering Committee and Ed-Tech Advisory Panel are needed

-
- Development and assessment of 21st Century Learning environment requirements (bandwidth and internetworking of LANs, WANs, and consortium application and services) necessary to deliver support cost sharing capability under:
 - Student Systems – Electronic content and curriculum, access and distribution
 - Teacher Development – Professional Development Programs with IT systems and Ed-tech tools
 - Information Systems Coordination – Networking, applications, and data management
 - Finding and implementing carrier and partner aggregation points across the state for EAGLE-Net Gateway routing and interconnectivity between the core EAGLE-Net Gateway and UPoP facility in Denver
 - Planning for 2009-2010 aggregation expansion to Northwest, West, West Central, and Southwest portions of Colorado
 - Continue preparing and submitting applications for grant funding within Federal and State Grant programs and Private Foundations; all of which have been key to date in acquiring hardware, fiber optic connectivity, interconnection, and co-location during the initial start up. Ongoing funding requirements for capital for aggregation hardware and inter-networking transport facilities must continue until EAGLE-Net participation grows to the point of self sustainability
 - Deliver a unified request to the new Federal Administration for infrastructure build dollars to get the long haul and aggregation locations interconnected sooner than later
 - Develop a stronger distance learning and video conferencing collaboration between K-12 and Higher Education and the rural clinics and hospitals (Colorado Telehealth Network / CTN; <http://www.cotelehealth.com>) to enable a better system for critical communications and growth between rural and urban environments

ADDITIONAL RESOURCES

An Action Plan for America: Using Technology and Innovation to Address our Nation's Critical Challenges. A report for the next administration, by the Benton Foundation.

http://www.benton.org/initiatives/broadband_benefits/action_plan

A Blueprint for Big Broadband, An EDUCAUSE White Paper, January 2008,

<http://www.educause.edu/ir/library/pdf/EPO0801.pdf>

and

<http://www.internet2.edu/presentations/spring08/20080423-blueprint-windhausen.pdf>